

External Air Switch Kit Installation

DSA-EAS

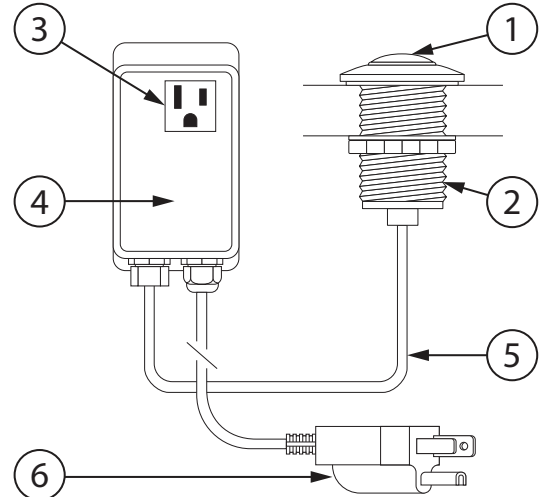

- | | |
|----------------|-----------------|
| 1) Button | 4) Power Module |
| 2) Button Body | 5) Soft Tube |
| 3) AC Socket | 6) Power Plug |

Installation

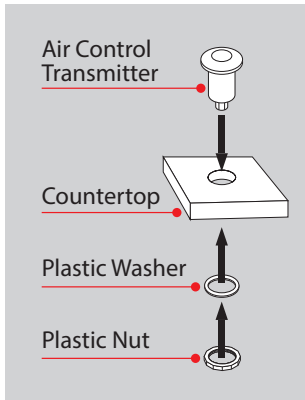

- Mount the push button directly through a standard sink hole or through the counter top by drilling a 1-1/4" diameter hole.
- Place the plastic washer between plastic nut and the bottom of sink counter.
- Tighten the plastic nut under the sink counter to ensure a watertight seal.

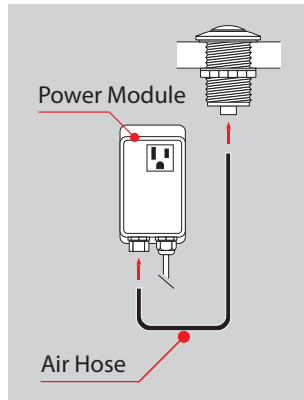

- Attach air tubing between push button and power module.
- Push the tubing tightly onto the molded protrusions.

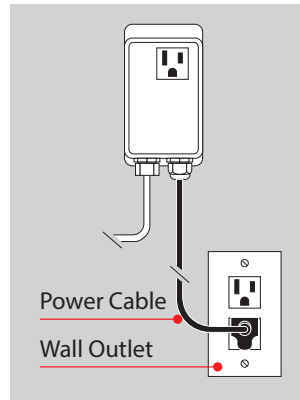

- Plug power module into a dedicated, grounded 220V/120V A/C outlet that is continuously energized.

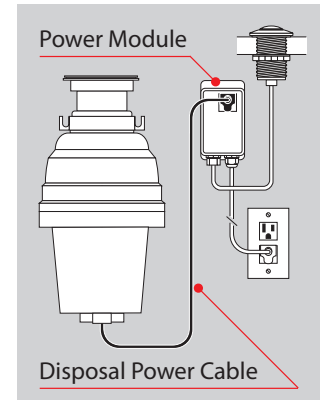

- Plug disposal cord into power module.
- Press push button to ensure that the Countertop Switch turns the disposal on and off.

NOTE: Disposal may start when disposal cord is plugged into the power module. Push the Air Switch button once to stop the disposal.

Be sure that the control system is operating properly before using the unit. Press and release the Countertop Switch button to turn the disposal on. Press and release again to turn the disposal off.

For Ordering Call: 954-987-3430
or Fax: 954-987-3434

Product Spec Sheet