

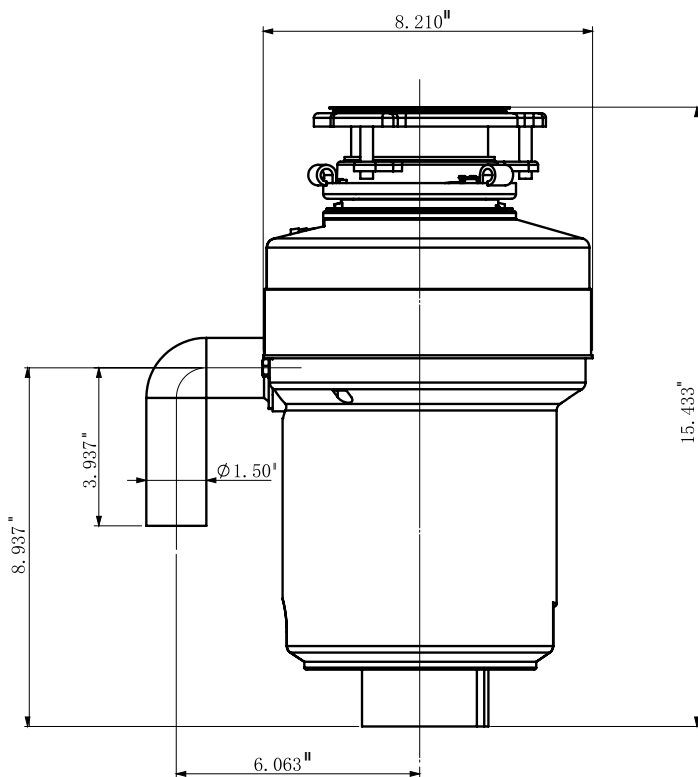

# DSA-WD3001

## GARBAGE DISPOSAL UNIT



### Style:

- 3/4 hp Garbage Disposal
- With Built-In Air Switch



### Features:

- Universal Drain Fitment
- Permanent Magnet DC Motor
- Whisper Quiet
- 2500 RPM
- 120v / 60 Hz
- Continuous Feed
- Built-in air switch
- Septic system safe
- Permanently sealed bearings
- Stainless steel grind ring, balanced turntable, & balanced armature shaft
- Cast stainless steel swivel impeller & cutting mechanisms means no rust
- Thermoset polymer drain housing
- PA hopper & manual reset
- Hardwire or Plug-in friendly

### Included:

- Air Switch (Brushed Nickel)
- Power Cord
- 3 bolt connector and sink flange with stopper
- Drain Connector (elbow)

### Warranty:

- 10 Year Limited Warranty

